



Chip Inductors – 0805HQ Series (2012)

The 0805HQ Series offers our highest Q factors in an 0805 form factor. In addition, current handling has been improved with significantly lower DCR values.

Like all Coilcraft wire wound ceramic chip inductors, the 0805HQ Series provides exceptional SRFs, tight inductance tolerance and batch consistency.

For even higher Qs, consider our surface mount spring inductors that combine the high Q of an air wound coil with the convenience of automatic placement.

Coilcraft **Designer's Kit C325** contains samples of all 5% inductance tolerance parts. To order, contact Coilcraft or visit <http://order.coilcraft.com>.

Part number ¹	Inductance ² (nH)	Percent tolerance ³	Q min ⁴	SRF min ⁵ (GHz)	DCR max ⁶ (Ohms)	Irms ⁷ (A)	Color code
0805HQ-2N5X_L_	2.5 @ 250 MHz	5	80 @ 1500 MHz	10.30	0.020	1.6	Black
0805HQ-5N6X_L_	5.6 @ 250 MHz	5	98 @ 1500 MHz	6.10	0.035	1.6	Brown
0805HQ-6N2X_L_	6.2 @ 250 MHz	5	88 @ 1000 MHz	4.75	0.035	1.6	Red
0805HQ-12NX_L_	12 @ 250 MHz	5	80 @ 1000 MHz	3.00	0.045	1.6	Orange
0805HQ-16NX_L_	16 @ 250 MHz	5,2	72 @ 500 MHz	2.95	0.060	1.5	Yellow
0805HQ-18NX_L_	18 @ 250 MHz	5,2	75 @ 500 MHz	2.55	0.060	1.4	Green
0805HQ-20NX_L_	20 @ 250 MHz	5,2	70 @ 500 MHz	2.05	0.055	1.4	Blue
0805HQ-27NX_L_	27 @ 250 MHz	5,2	75 @ 500 MHz	2.00	0.070	1.3	Violet
0805HQ-30NX_L_	30 @ 250 MHz	5,2	65 @ 500 MHz	1.95	0.095	1.2	Gray
0805HQ-39NX_L_	39 @ 250 MHz	5,2	65 @ 500 MHz	1.60	0.110	1.1	White
0805HQ-48NX_L_	48 @ 200 MHz	5,2	65 @ 500 MHz	1.40	0.095	1.2	Black
0805HQ-51NX_L_	51 @ 200 MHz	5,2	65 @ 500 MHz	1.40	0.120	1.0	Brown

1. When ordering, specify **tolerance, termination and packaging** codes:

0805HQ-51NX J L C

- Tolerance:** G = 2% J = 5% (Table shows stock tolerances in bold.)
- Termination:** L = RoHS compliant silver-palladium-platinum-glass frit. Special order: T = RoHS tin-silver-copper (95.5/4/0.5) or S = non-RoHS tin-lead (63/37).
- Packaging:** C = 7" machine-ready reel. EIA-481 embossed plastic tape (2000 parts per full reel).
B = Less than full reel. In tape, but not machine ready. To have a leader and trailer added (\$25 charge), use code letter C instead.
D = 13" machine-ready reel. EIA-481 embossed plastic tape. Factory order only, not stocked (7500 parts per full reel).

2. Inductance measured using a Coilcraft SMD-A fixture in an Agilent/HP 4286 impedance analyzer with Coilcraft-provided correlation pieces.
3. Tolerances in bold are stocked for immediate shipment.
4. Q measured using an Agilent/HP 4291A with an Agilent/HP 16193 test fixture.

5. For SRF less than 6 GHz, measured using an Agilent/HP 8753D network analyzer and a Coilcraft SMD-D test fixture. For SRF greater than 6 GHz, measured using an Agilent/HP 8722ES network analyzer and a Coilcraft SMD-D test fixture.
6. DCR measured on a Cambridge Technology micro-ohmmeter and a Coilcraft CCF840 test fixture.
7. Current that causes a 15°C temperature rise from 25°C ambient.
8. **Ambient temperature range:** -40°C to +125°C with I_{rms} current +125°C to +140°C with derated current
9. **Storage temperature range:** Component: -40°C to +140°C
Packaging: -55°C to +80°C
10. **Resistance to soldering heat:** Three reflows at >217°C for 90 seconds (+260°C ±5°C for 20–40 seconds), allowing parts to cool to room temperature between.
11. Electrical specifications at 25°C.
12. Temperature coefficient of inductance: +25 to +125 ppm/°C. See Qualification Standards section for environmental and test data. Refer to Doc 362 "Soldering Surface Mount Components" before soldering.

COILCRAFT ACCURATE
PRECISION REPEATABLE
MEASUREMENTS
SEE INDEX **TEST FIXTURES**

Coilcraft[®]

Specifications subject to change without notice.
Please check our website for latest information.

Document 197-1 Revised 09/21/07

1102 Silver Lake Road Cary, Illinois 60013 Phone 847/639-6400 Fax 847/639-1469
E-mail info@coilcraft.com Web <http://www.coilcraft.com>



Chip Inductors 0805HQ Series (2012)

S-Parameter files
ON OUR WEB SITE OR CD
SPICE models
ON OUR WEB SITE OR CD

Typical Q vs Frequency

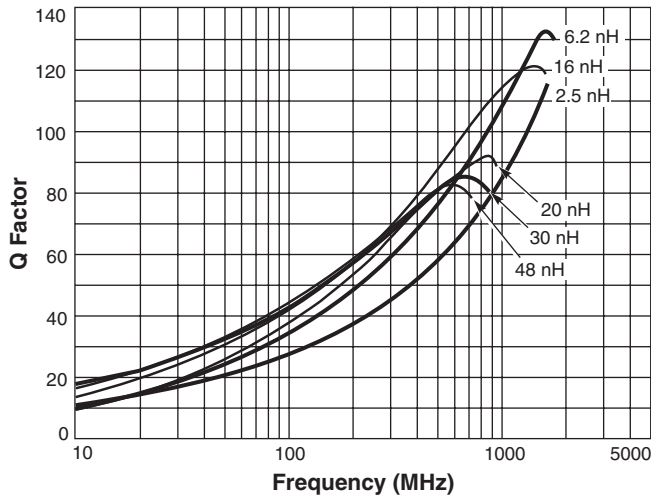

Typical L vs Frequency

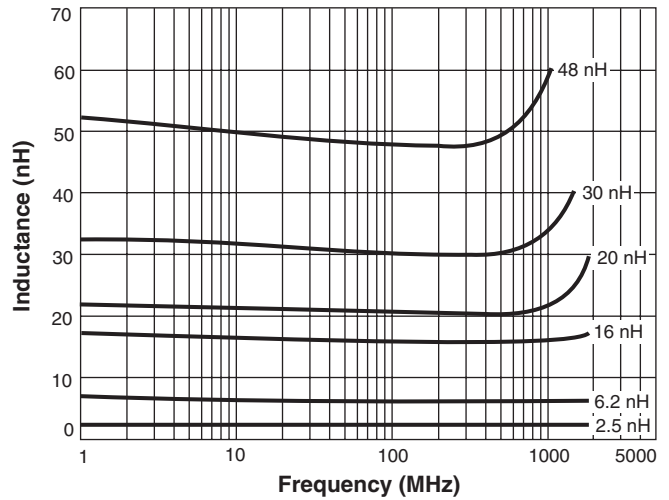

Irms Derating

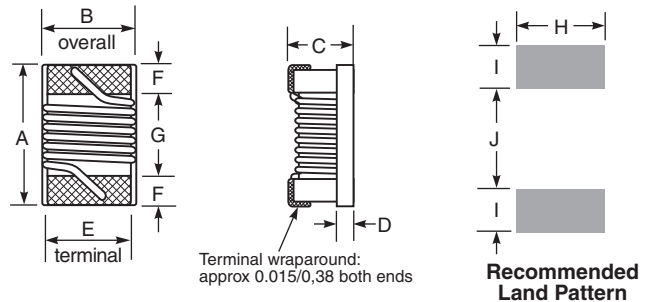
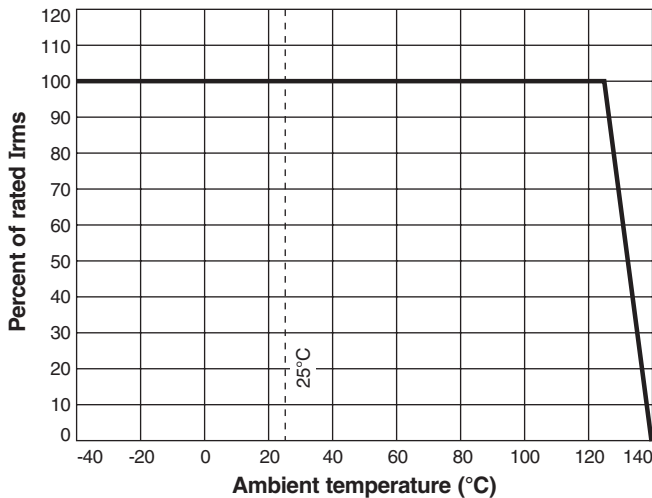

A	B	C	D	E	F	G	H	I	J
max	max	max	ref						
0.090	0.068	0.060	0.020	0.050	0.020	0.040	0.070	0.040	0.030
2,29	1,73	1,52	0,51	1,27	0,51	1,02	1,78	1,02	0,76

Weight: 10.5 – 12.5 mg
Tape and reel: 2000/7" reel; 7500/13" reel 8 mm tape width
For packaging data see Tape and Reel Specifications section.



Specifications subject to change without notice.
Please check our website for latest information.

Document 197-2 Revised 09/21/07

1102 Silver Lake Road Cary, Illinois 60013 Phone 847/639-6400 Fax 847/639-1469

E-mail info@coilcraft.com Web <http://www.coilcraft.com>