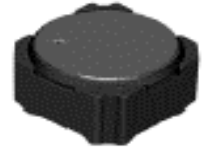
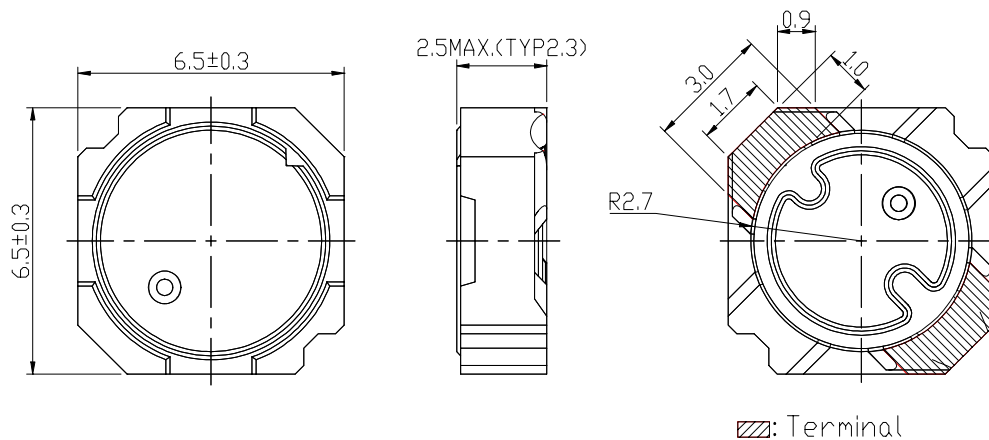
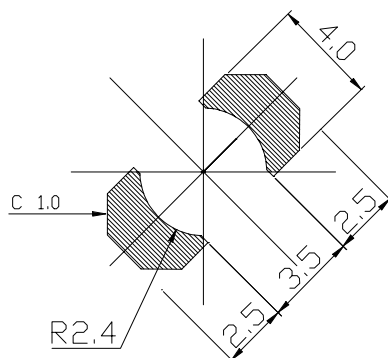

Type: CDR6D23MN
◆ Product Description

- 6.8×6.8mm Max.(L×W), 2.5mm Max. Height.
- Inductance range: 0.6~100 μ H
- Rated current range: 0.41~4.6A
- In addition to the standard versions of inductors shown here, custom inductors are available to meet your exact requirements.

◆ Feature

- Magnetically shielded construction.
- Hybrid power inductors use Mn-Zn D.core & Ni-Zn R.core, used as general power inductors.
- Higher saturation current characteristics than that of Ni-Zn inductors.
- Usually used in LCD driver,DSC/DVC,Notebook PC or the other portable equipment,.
- RoHS Compliance.

◆ Dimensions (mm)

◆ Land Pattern (mm)

Type: CDR6D23MN
◆ Specification

Part Name ※	Stamp	Inductance [Within] (100kHz/1V)	D.C.R.(mΩ) Max.(Typ.) (at 20°C)	Saturation Current (A)※1		Temperature Rise Current (A)※2
				(at 20°C)	(at 105°C)	
CDR6D23MNNP-ØR6N□	0R6	0.6 μH ±25%	20.0(16)	6.55	4.95	4.60
CDR6D23MNNP-1R0N□	1R0	1.0 μH ±25%	25.0(20)	5.15	4.00	3.90
CDR6D23MNNP-1R5N□	1R5	1.5 μH ±25%	28.0(22)	4.40	3.55	3.30
CDR6D23MNNP-2R0N□	2R0	2.0 μH ±25%	36.3(29)	3.85	3.05	2.60
CDR6D23MNNP-2R7N□	2R7	2.7 μH ±25%	40.0(32)	3.30	2.60	2.38
CDR6D23MNNP-3R3N□	3R3	3.3 μH ±25%	46.3(37)	2.95	2.30	2.25
CDR6D23MNNP-4R2N□	4R2	4.2 μH ±25%	52.5(42)	2.60	2.10	2.05
CDR6D23MNNP-5R1N□	5R1	5.1 μH ±25%	60.0(48)	2.45	1.95	1.90
CDR6D23MNNP-6R1N□	6R1	6.1 μH ±25%	66.3(53)	2.30	1.75	1.80
CDR6D23MNNP-7R2N□	7R2	7.2 μH ±25%	72.5(58)	2.10	1.60	1.70
CDR6D23MNNP-8R3N□	8R3	8.3 μH ±25%	80.0(64)	1.95	1.50	1.50
CDR6D23MNNP-1Ø0N□	100	10 μH ±25%	103.8(83)	1.75	1.40	1.30
CDR6D23MNNP-12ØN□	120	12 μH ±25%	117.5(94)	1.55	1.25	1.25
CDR6D23MNNP-15ØN□	150	15 μH ±25%	133.8(107)	1.40	1.15	1.10
CDR6D23MNNP-18ØN□	180	18 μH ±25%	158.8(127)	1.30	1.05	1.00
CDR6D23MNNP-22ØN□	220	22 μH ±25%	187.5(150)	1.20	0.95	0.80
CDR6D23MNNP-27ØN□	270	27 μH ±25%	255.0(204)	1.05	0.85	0.75
CDR6D23MNNP-33ØN□	330	33 μH ±25%	275.0(220)	0.95	0.75	0.70
CDR6D23MNNP-39ØN□	390	39 μH ±25%	393.8(315)	0.90	0.70	0.58
CDR6D23MNNP-47ØN□	470	47 μH ±25%	456.3(365)	0.80	0.60	0.54
CDR6D23MNNP-56ØN□	560	56 μH ±25%	481.2(385)	0.75	0.58	0.51
CDR6D23MNNP-68ØN□	680	68 μH ±25%	751.3(601)	0.65	0.53	0.45
CDR6D23MNNP-82ØN□	820	82 μH ±25%	803.8(643)	0.60	0.47	0.43
CDR6D23MNNP-1Ø1N□	101	100 μH ±25%	903.8(723)	0.55	0.44	0.41

※ Description of part name

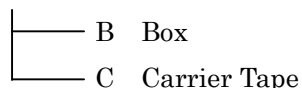
CDR6D23MNNP-ØR6N□



※1. Saturation current: The DC current at which the inductance decreases to 65% of its initial value.

※2. Temperature rise current: The DC current at which the temperature rise is Δt=40°C. (Ta=20°C).